



PROPERTY FOR SALE

2725 S. COMBEE RD., LAKELAND, FL

877.518.5263 | SVNsaunders.com | 114 N. Tennessee Ave. Lakeland, FL 33801

TABLE OF CONTENTS

- 3 EXECUTIVE SUMMARY
- 4 MAPS
- 6 DEMOGRAPHICS
- 9 AERIAL VIEWS
- 14 ADDITIONAL PHOTOS

Glenn Folsom

Senior Advisor
glenn.folsom@svn.com

863.877.0632



CONFIDENTIALITY & DISCLAIMER

©2019 SVN | Saunders Ralston Dantzler Real Estate, All rights Reserved, makes every attempt to provide accurate information on this property, however, does not guarantee the accuracy. Buyer should rely entirely on their own research, inspection of property, and records.

EXECUTIVE SUMMARY

2725 S. COMBEE RD LAKELAND, FL

The subject property is a industrial manufacturing facility that consists of approximately 61,400 SF on 11.79 Acres. The property served as an Animal Feed Mill since 1963, and is well located within an industrial neighborhood that provides easy access to US 98, the Polk Parkway, I-4 and SR 60.

The property features a beautiful office space, multiple warehouse spaces, rail spur, truck scale, and ample equipment to serve a variety of industrial users.

Site Address:	2725 Combee Rd S, Lakeland, FL 33803
County:	Polk
PIN (Property Identification Number):	24-28-28-000000-022020
Land Size:	11.79 +/- Acres
Building Size:	61,400 +/- SF
Year Built:	1963
Property Use:	Light Manufacturing
Utilities:	Available - Polk County
Future Land Use:	BPC-2X [Polk County]
Taxes:	\$16,788 [2019]
Traffic Count:	42,000 cars/day on US 98
Asking Price:	\$2,295,000



Located in the Lakeland - Winter Haven MSA, between Tampa and Orlando, in the center of the I-4 Corridor.

REGIONAL LOCATION

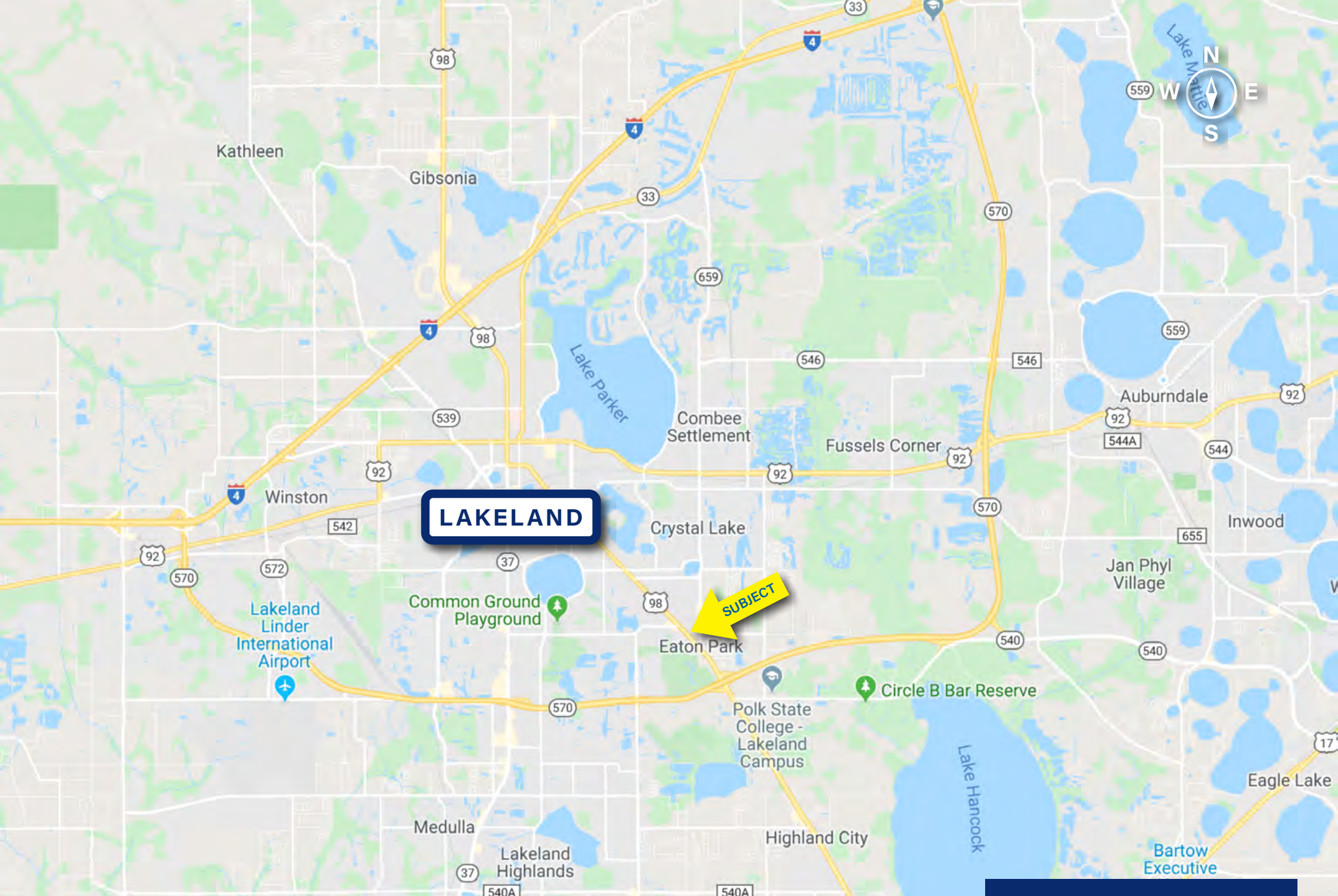

Located just North of the Polk Parkway, in East Lakeland.

LOCATION MAP

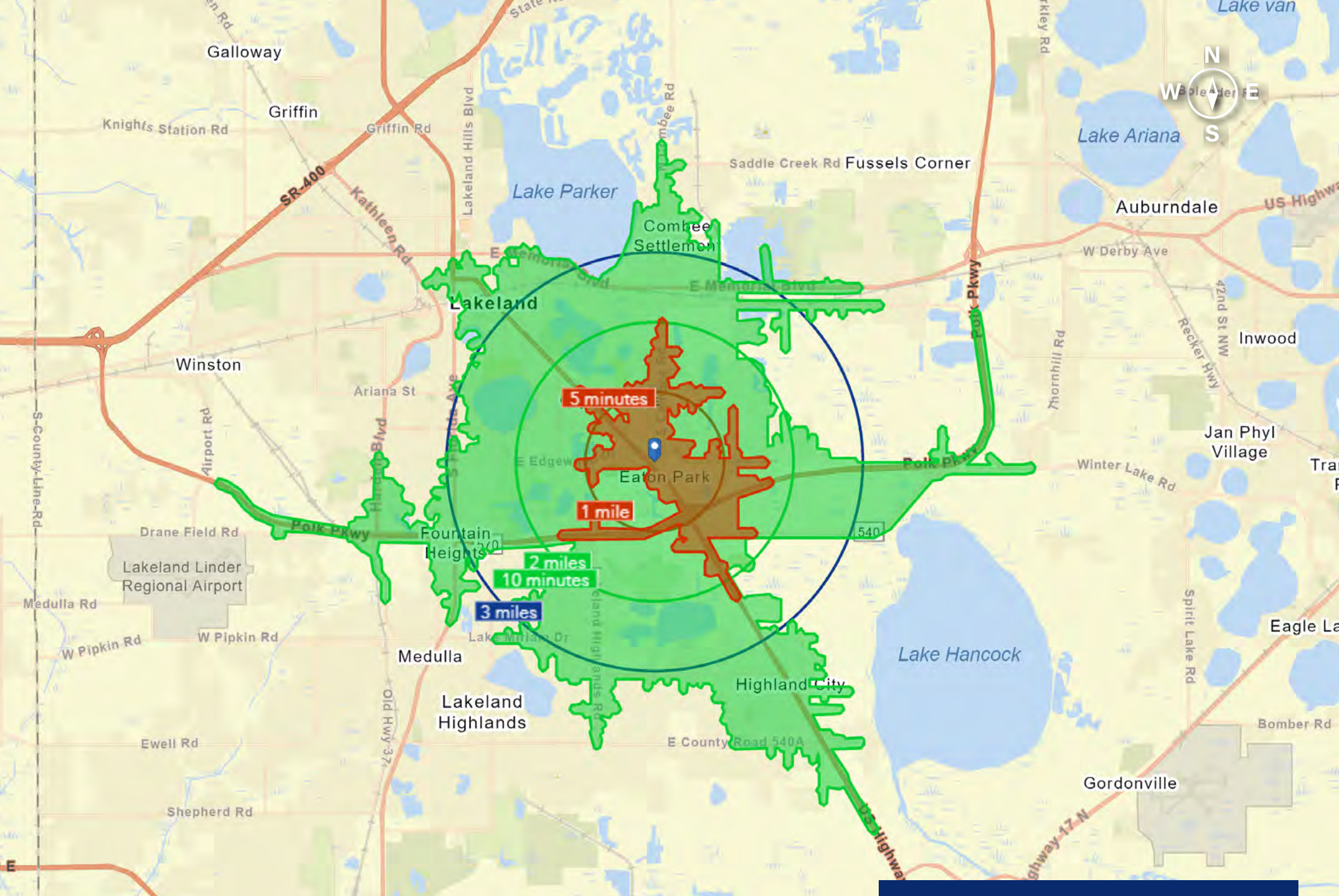

1, 2, 3 mile radius
5, 10 minute drive time

DEMOGRAPHICS MAP

BENCHMARK DEMOGRAPHICS

	1 Mile	2 Miles	3 Miles	5 Mins	10 Mins	Polk	FL	US
Population	7,294	26,033	50,682	6,689	62,525	683,954	21,239,528	332,417,793
Households	2,785	9,831	19,083	2,444	23,770	255,025	8,299,404	125,168,557
Families	1,740	6,173	12,200	1,600	14,961	177,233	5,366,533	82,295,074
Average Household Size	2.62	2.52	2.52	2.71	2.50	2.63	2.51	2.59
Owner Occupied Housing Units	1,347	5,316	11,044	1,167	13,300	174,808	5,375,035	79,459,278
Renter Occupied Housing Units	1,438	4,514	8,039	1,277	10,469	80,217	2,924,369	45,709,279
Median Age	35.3	35.7	37.0	34.0	37.1	41.6	42.5	38.5
Income								
Median Household Income	\$38,075	\$42,487	\$49,517	\$40,115	\$47,461	\$50,006	\$54,238	\$60,548
Average Household Income	\$50,811	\$59,694	\$71,093	\$53,299	\$67,277	\$67,890	\$78,335	\$87,398
Per Capita Income	\$19,087	\$22,478	\$26,815	\$19,076	\$25,458	\$25,412	\$30,703	\$33,028
Trends: 2015 - 2020 Annual Growth Rate								
Population	1.14%	0.94%	0.85%	1.19%	0.95%	1.46%	1.37%	0.77%
Households	1.05%	0.87%	0.78%	1.07%	0.90%	1.37%	1.31%	0.75%
Families	0.95%	0.78%	0.69%	0.97%	0.79%	1.31%	1.26%	0.68%
Owner HHs	1.06%	1.11%	1.01%	1.45%	1.17%	1.72%	1.60%	0.92%
Median Household Income	2.25%	2.65%	2.02%	2.37%	2.19%	1.95%	2.37%	2.70%

There is good population density within a 2 mile radius of 26,033 people.

BENCHMARK DEMOGRAPHICS

1 Mile 2 Miles 3 Miles 5 Mins 10 Mins Polk FL US

Households by Income

	1 Mile	2 Miles	3 Miles	5 Mins	10 Mins	Polk	FL	US
<\$15,000	19.30%	16.70%	13.00%	18.00%	13.30%	12.10%	11.10%	10.70%
\$15,000 - \$24,999	11.50%	11.10%	10.30%	11.00%	11.30%	10.60%	10.10%	9.00%
\$25,000 - \$34,999	13.90%	11.50%	10.30%	12.60%	10.60%	10.70%	10.10%	8.90%
\$35,000 - \$49,999	19.50%	18.20%	16.80%	19.80%	16.90%	16.50%	14.40%	12.40%
\$50,000 - \$74,999	19.30%	19.10%	18.20%	19.70%	18.30%	19.00%	18.50%	17.50%
\$75,000 - \$99,999	6.70%	9.40%	10.90%	8.60%	11.30%	12.70%	12.30%	12.60%
\$100,000 - \$149,999	6.70%	8.50%	11.60%	7.10%	10.70%	11.20%	12.80%	15.10%
\$150,000 - \$199,999	0.90%	2.40%	4.20%	1.10%	3.70%	3.50%	5.00%	6.50%
\$200,000+	2.20%	3.20%	4.70%	2.30%	3.90%	3.60%	5.70%	7.30%

Population by Age

	1 Mile	2 Miles	3 Miles	5 Mins	10 Mins	Polk	FL	US
0 - 4	7.50%	6.20%	5.60%	7.30%	5.80%	5.90%	5.20%	6.00%
5 - 9	7.10%	6.00%	5.60%	7.10%	5.70%	6.00%	5.40%	6.10%
10 - 14	6.40%	5.80%	5.60%	6.70%	5.70%	6.00%	5.60%	6.30%
15 - 19	5.90%	7.60%	7.90%	6.70%	7.50%	5.90%	5.60%	6.30%
20 - 24	7.00%	8.90%	8.70%	7.60%	8.30%	5.70%	6.10%	6.70%
25 - 34	15.80%	14.60%	14.10%	15.90%	14.40%	12.90%	13.30%	14.00%
35 - 44	11.70%	11.40%	11.30%	12.20%	11.70%	11.40%	11.70%	12.60%
45 - 54	11.00%	10.80%	11.30%	11.40%	11.60%	11.70%	12.50%	12.50%
55 - 64	11.60%	11.80%	12.60%	11.60%	12.50%	13.10%	13.70%	13.10%
65 - 74	9.00%	9.50%	9.90%	7.90%	9.60%	12.20%	11.70%	9.70%
75 - 84	5.30%	5.40%	5.30%	4.00%	5.10%	6.80%	6.50%	4.70%
85+	1.70%	2.00%	2.00%	1.40%	2.10%	2.50%	2.80%	2.00%

Race and Ethnicity

	1 Mile	2 Miles	3 Miles	5 Mins	10 Mins	Polk	FL	US
White Alone	61.90%	70.20%	75.50%	63.00%	74.50%	71.50%	72.70%	69.60%
Black Alone	21.70%	16.80%	13.10%	22.50%	13.50%	15.60%	16.50%	12.90%
American Indian Alone	0.40%	0.40%	0.40%	0.40%	0.40%	0.50%	0.40%	1.00%
Asian Alone	1.90%	1.90%	2.10%	1.80%	2.40%	1.80%	2.90%	5.80%
Pacific Islander Alone	0.20%	0.10%	0.10%	0.20%	0.10%	0.10%	0.10%	0.20%
Some Other Race Alone	9.40%	6.40%	5.20%	7.50%	5.50%	7.40%	4.50%	7.00%
Two or More Races	4.60%	4.10%	3.60%	4.50%	3.60%	3.10%	3.10%	3.50%
Hispanic Origin (Any Race)	22.70%	19.60%	17.80%	21.20%	18.60%	24.00%	26.60%	18.60%

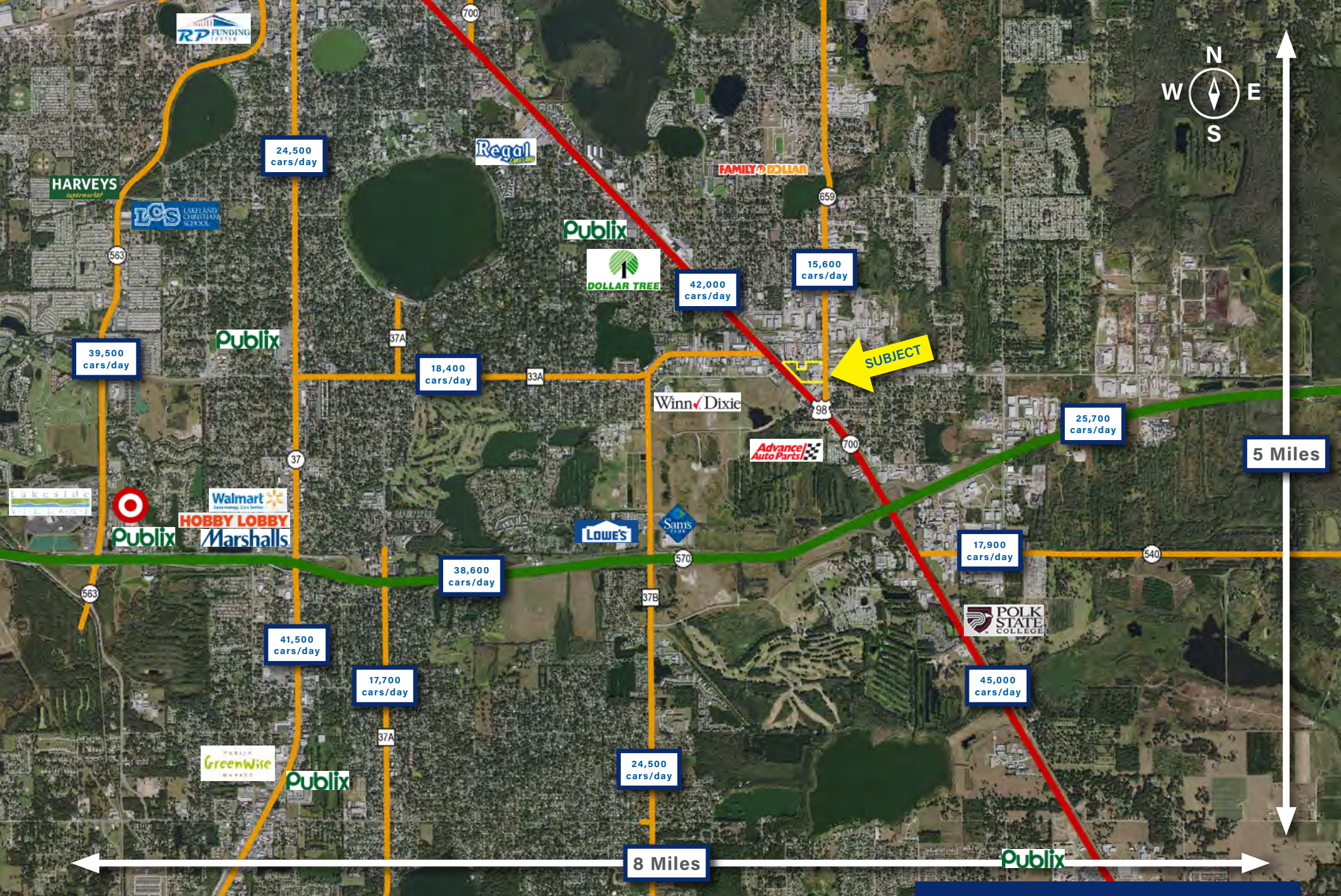

The market area has excellent road systems connecting the property to I-4 as well as south Polk County.

MARKET AREA MAP

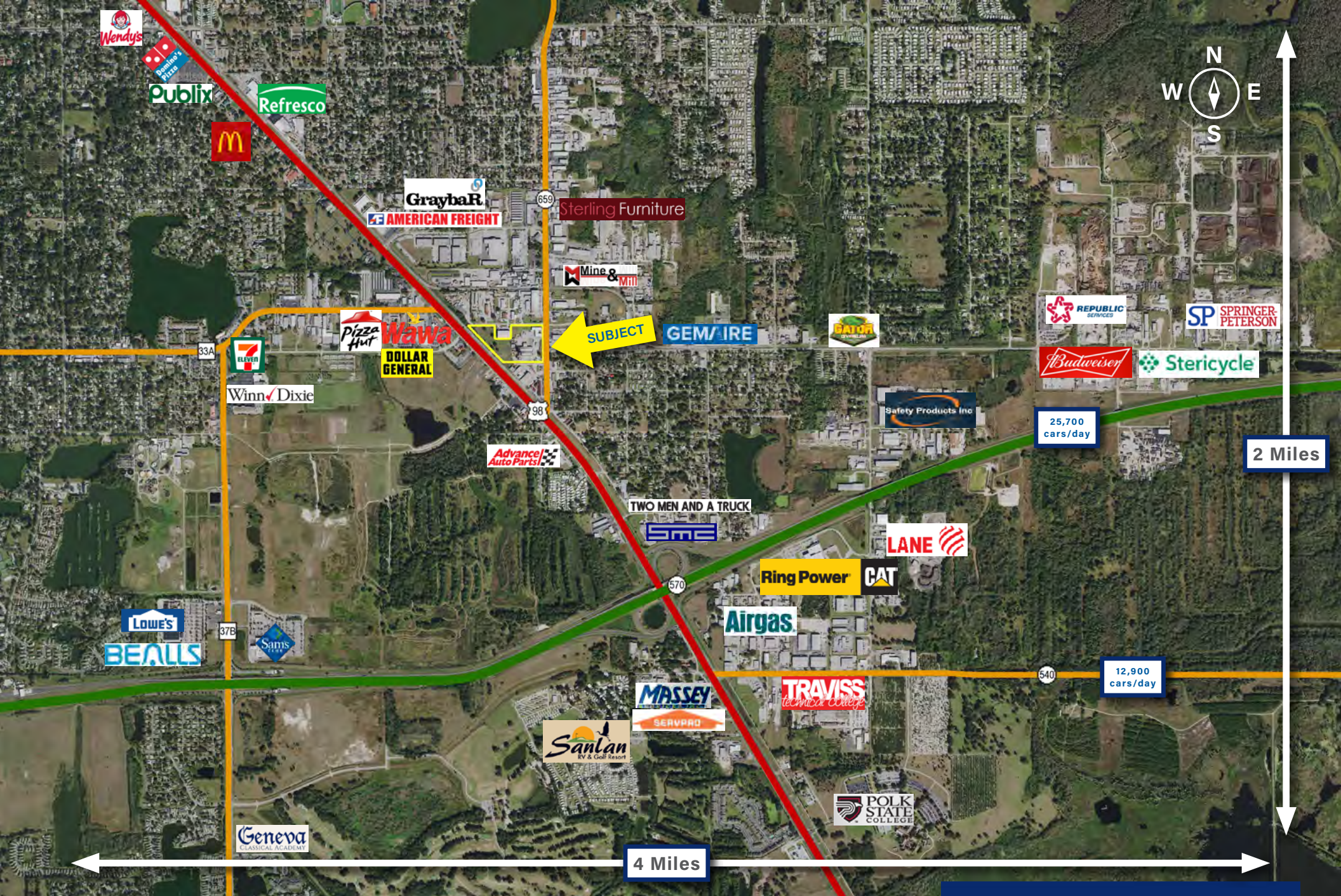

The southern portion of the trade area is mostly residential while the northern portion is industrial and retail.

TRADE AREA MAP



The property is located within a strong industrial neighborhood in East Lakeland.

NEIGHBORHOOD AERIAL



The property has great visibility from US Highway 98 and Combee Rd.

SITE AERIAL

BUILDING INFORMATION

Building 1

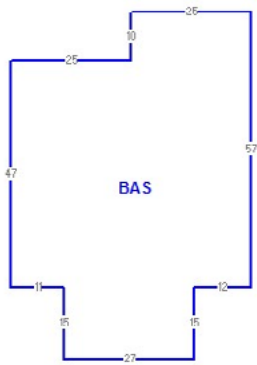

Building 2

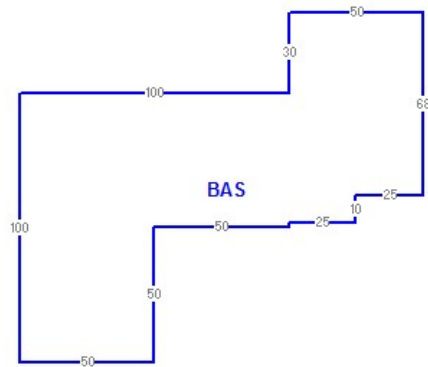

Building 3

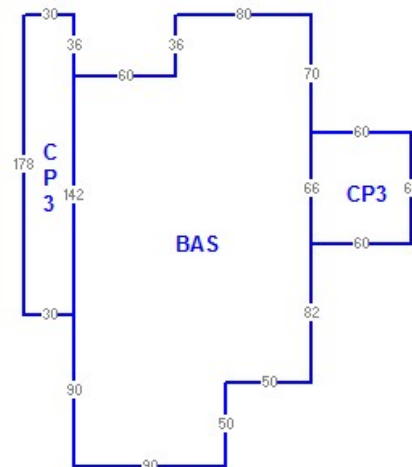

Building 4

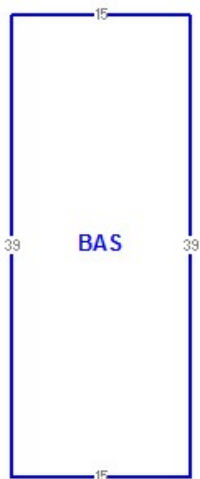

Building 5

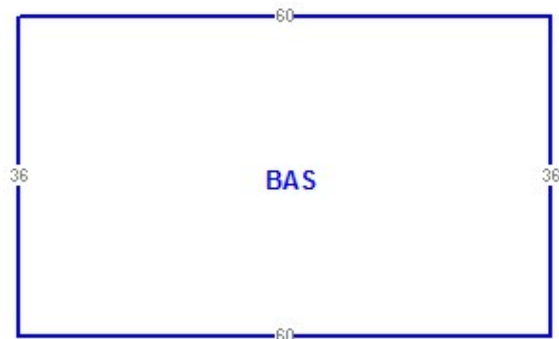

Building 6

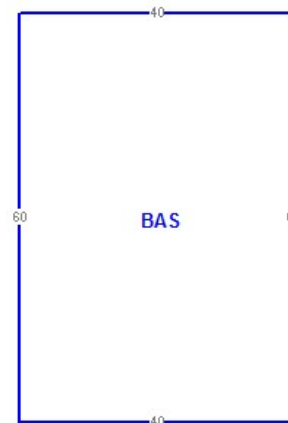

Description

Total:

Building 1	3,005 +/- Total SF
Building 2	11,150 +/- Total SF
Building 3	42,160 +/- Total SF
Building 4	585 +/- Total SF
Building 5	2,160 +/- Total SF
Building 6	2,400 +/- Total SF

There are a total of six buildings that range in date constructed from 1960 to 2016.



Exterior Entrance



Main Lobby



Office Space



Break Room



Exterior



Rail Dock



Large Mill Cooler and Screener Area



Pallet Line Packaging



Interior



Feed Mill



Property from additional acreage



Operational Truck scale



Aerial Facing SW



Aerial Facing S



Aerial Facing N

ZONING

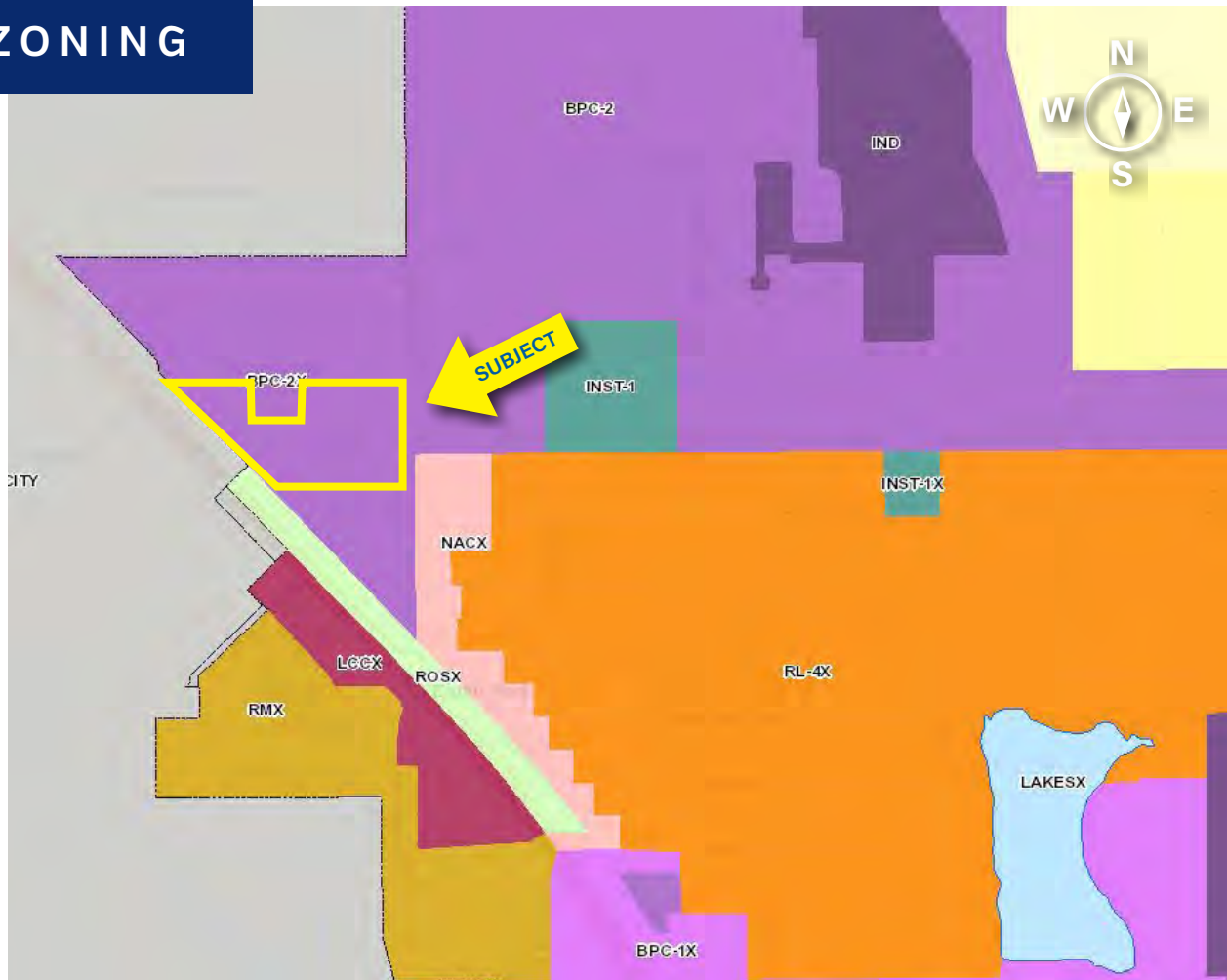

Business Park Center (BPC-2X)

This Selected Area Plan (SAP) was adopted in the Polk County Comprehensive Plan to recognize the anticipated high level of urbanization during the next twenty years along the US Highway 98 corridor between the Cities of Lakeland and Bartow. The districts and performance standards that follow implement the initiatives outlined in the Plan. In order to achieve an efficient, sustainable, and highly desirable urban growth pattern, a balance of residential and non-residential uses, wide range of housing types and choices, and short trips between housing, employment, and shopping are all required. Pedestrian and bicycle connections between development will help reduce the need for short vehicular trips and better accommodate those not able to drive. The Fort Fraser Trail is an important nonmotorized, linear pedestrian connection linking all development within this SAP and needs to be protected from incompatible uses and connected to all development by a network of sidewalks and bike lanes. Access management required in this section is consistent with the Florida Department of Transportation's (DOT) US Highway 98 Corridor Access Management Plan (CAMP).

-  BPC-2X
-  RL-4X
-  LCCX
-  RMX

-  NACX
-  INST-1



SVN | Saunders Ralston Dantzler
Real Estate

877.518.5263

114 N. Tennessee Ave.
Lakeland, FL 33801